

- Read and experiment with each step
- To perform automatic or multi-point tests*, refer to the Door Fan Software Manual and the DM-2 Operator's Manual

*Tests for CGSB 149, LEED, ASTM E778, ASTM 1827, EN13829, and ATTMA TS-1 may require more elaborate steps and training. This guide is intended only for familiarization with the controls.

For the latest Retrotec documentation, visit us at: <http://www.retrotec.com/info/>

Fans must be plugged into three separate circuits!

1 Charge DM-2 batteries

- 1.1 Plug in the battery charger or the power connection from the fan.
- 1.2 Install 4 NiMH AA batteries.
- 1.3 Press **[On]** **[Exit]** to start the DM-2 and to clear the intro screen.
- 1.4 Charge batteries until full (up to 12 hrs.) and disconnect the battery charger.



Note Run the DM-2 on batteries until the indicator displays 1/4 charge, and then recharge fully, to increase battery life.

See: QuickGuide-DM2MkII



2 Set up the building

- 2.1 Close the outside doors and windows.
- 2.2 Open all interior doors leading to conditioned spaces.
- 2.3 Shut off HVAC (exhaust fans, dryers, A/C, furnaces).
- 2.4 Turn gas hot water to pilot.
- 2.5 Place paper over any open ashes.



Close all windows

Gas valve to Pilot

Cover ashes with paper

3 Unpack the fan panels

- 3.1 Remove the 3-fan panel from the case.
- 3.2 Stand the panel on its side, and unfold the sections.
- 3.3 Lock both panel sections using the butterfly latches (which are opposite the hinges).

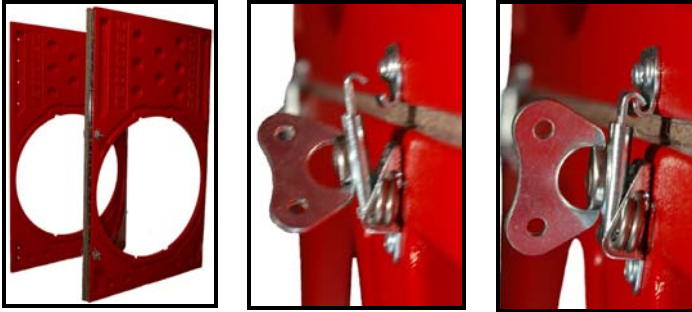

4 Position the panel

- 4.1 The panel must be placed so that the fan holes are on the same side as the door hinges.
- 4.2 The door should open in the opposite direction from the panel. Secure the door open.
- 4.3 The panel side which displays "Retrotec" must face towards the operator.

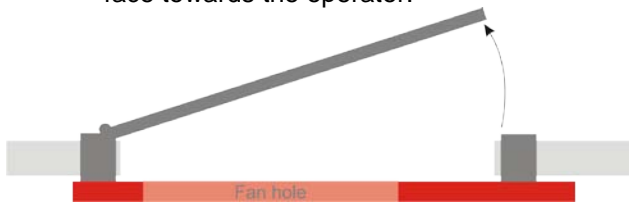

5 Secure the fan panel

- 5.1 Attach a retention strap to the top corner of the frame, nearest the door hinges.
- 5.2 Pull the anchor over the door, and in between the door and frame.
- 5.3 Tighten the strap until the panel is tight against the door frame.



6 Attach the fan straps

- 6.1 Attach the three fan straps, one for each fan hole.



7 Install the cross braces

- 7.1 Slide a locking collar and retention strap onto each end of the cross braces.



- 7.2 Take one cross brace and slide the flat end between the door and frame.



- 7.3 Attach the bolts from both retention straps to the top fan panel.

- 7.4 Tighten the retention straps and align the cross brace and white ring so that the panel is held tightly.

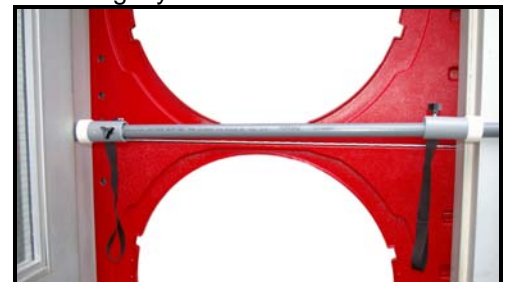

- 7.5 Secure the white ring in place by using the locking collar to pin the ring against the door frame.

- 7.6 Attach the second cross brace to the lower panel.

8 Install the corner brace

- 8.1 Install the corner brace in the top corner, on the opposite side of the door frame from the hinges.
- 8.2 Attach a retention strap to the door panel.



- 8.3 Slide the corner brace through the white ring.
- 8.4 Place the corner brace at a diagonal across the corner of the door frame.
- 8.5 Tighten the retention strap.

9 Seal any remaining gaps

- 9.1 Depending on the height of the doorway, a gap may be left open between the top of the panel and the door frame.
- 9.2 Use grill mask to seal the gap.



10 Install the fans

- 10.1 Remove the fans from their cases.
- 10.2 Install each fan in the panel by seating the base of the fan into the panel.
- 10.3 Align the notch on the top of the fan with the gap in the fan panel. Slide the notch through the panel.

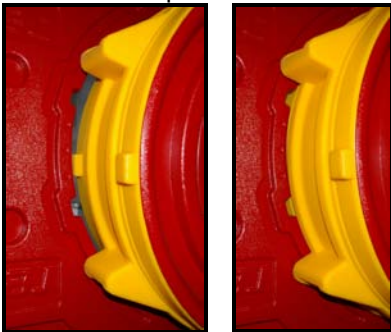

- 10.4 Rotate the fan slightly so that it rests securely in the fan panel.
- 10.5 Attach the fan strap to hold the fan in place.



11 Connect the fan umbilical

- 11.1 Connect each fan to one of the variable speed drives with the umbilical that is attached to the drives.
- 11.2 Connect the grey 230V Output cable from the Drive to the 230V Input port on the fan top.
- 11.3 Connect the yellow and green pressure tubes to the two ports on the fan top.

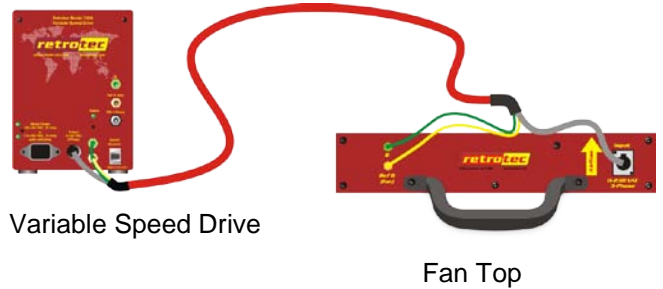

12 Connect DM-2 #1 to Drive

- 12.1 Connect DM-2 #1 to one variable speed Drive and to the splitter box, using the umbilical.
- 12.2 Connect the red, yellow, and green tubes from the umbilical to the DM-2. Connect the yellow Ethernet control cable to the DM-2.
- 12.3 Connect the yellow and green tubes (at the other end of the umbilical) to a variable speed drive unit.
- 12.4 Connect the yellow control cable to any port on the splitter box.

Note All ports on the splitter box function in parallel. There are no designated input and output ports.

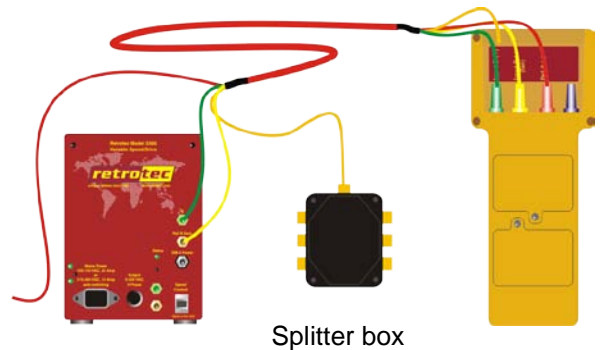

- 12.5 The remaining long red tube goes through the small hole in the bottom of the door panel. Ensure the tube end is out of the way of the fan air flow.

Note The fan speed control cables are Ethernet style but MUST NOT be connected to the Internet or to a laptop.

13 Connect the variable speed drives

- 13.1 Plug each Drive into a 20 amp outlet on an independent circuit for each Drive to avoid tripping the breaker. Tip: use a stove outlet.
- 13.2 Connect each drive unit to any port on the splitter box using the control cables.



14 Connect DM-2 #2

- 14.1 Connect DM-2 #2 to the remaining two variable speed drives.
- 14.2 Connect the yellow and green tubes between Channel A of DM-2 #2 and Drive #2.
- 14.3 Connect the red and blue tubes between Channel B of DM-2 #2 and Drive #3.

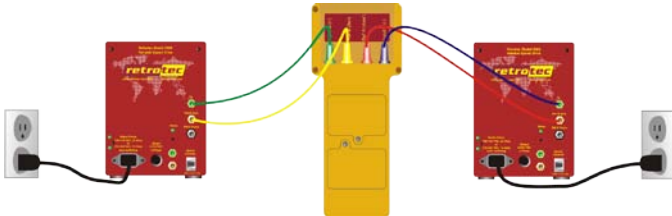

Note Channel A must be connected to any two ports on Drive #2. Channel B must be connected to any two ports on Drive #3.

- 14.4 The QMG is now set up.



15 Zero gauges



- 15.1 Press **[Auto Zero]**. When “On” is displayed, the gauge will zero itself every 8 seconds.
- 15.2 This needs to be done on both gauges.

Tip Normally, **[Auto Zero]** should be left “On”; turn off to save battery power.

16 Set time averaging



- 16.1 Press **[Time Avg]** as needed, until “PrA” varies by less than 1Pa.
- 16.2 Wait for twice the time average setting before taking a reading.
- 16.3 Do this for both gauges.

Example: Set **[Time Avg]** to “8s” then watch for 16 seconds.

- Tip** 1s, 2s, 4s, 8s updates every 1 second(s),
10s, 20s, 1min, 2min updates every 10 seconds.
- Tip** Use longer time averaging in windy conditions.

17 Measure bias pressure



- 17.1 Prior to each test, and with the fans covered, press **[Baseline]** on all gauges to begin averaging the bias pressure.
- 17.2 Press **[Enter]** after about 60 seconds to capture the “Baseline”.
- 17.3 After each test, press **[Exit]** to clear baseline.

Note The value displayed under “Baseline” will offset the influence of bias pressure on the pressure reading.

18 Set fan model on DM-2

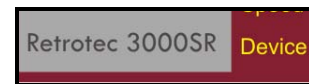

- 18.1 Press **[Device]** on DM-2 #1 until “Retrotec 3000SR” is displayed.
- 18.2 The 3000SR fan model has two pressure tubes attached. If only one pressure tube can be connected to the fan, set the **[Device]** to “Retrotec 3000”.

Tip Disable the other devices using **[Setup]** to prevent the incorrect flow curves from being accidentally accessed.

See: QuickGuide-DM2MkII

19 Remove fan cover and set range

- 19.1 Remove the fan covers from all three fans.
- 19.2 All three fans should be open, with all range plates removed.
- 19.3 Press **[Range Config]** on DM-2 #1 only, until “Open” is displayed.



See: QuickGuide-Fan-RangeConfig-2000&3000

20 Set speed manually



20.1 On DM-2 #1 connected to the splitter box, press **[Set Speed] [10-100] [Enter]** to set any speed from 10 to 100%.

Tip Press **[Exit]** to turn the fan off.

20.2 Press **[Jog/Hold]** until “Jog” appears. This enables manual fan speed adjustment.



20.3 Use **[▲] [▼]** to adjust the fan speed up or down.

Tip Click once to change speed by 1%, hold button to increment by 5%.

- 20.4 All 3 fans should run at the same speed.
- 20.5 Adjust the fans’ speed to achieve the lowest required test pressure to check to see if the flow is “TOO LOW” on Channel B of DM-2 #1.
- 20.6 Adjust the fans’ speed to achieve the highest required test pressure.

“TOO LOW” is displayed

Press **[Mode]**, on DM-2 #1, to display “Flow”. If PrA has been reached, but “TOO LOW” appears, the fans are running too slowly to measure flow.

1. Press **[Exit]** to stop the fans.
2. Remove one fan and install a blanking plate in the panel.
3. Restart the fans and try again.

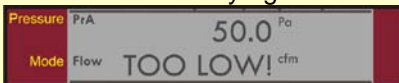

Note The displayed flow is the flow for Fan #1 only. It is not the reading of the combined flow for all three fans.

21 Set pressure automatically

21.1 Press **[Set Pressure] [10-90] [Enter]**. The DM-2 will control the fans to achieve the set pressure.

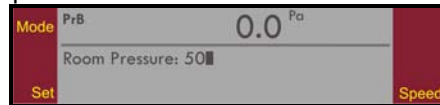

Example: Press **[Set Pressure] [50] [Enter]** to instruct the DM-2 to attempt to achieve 50Pa building pressure.

21.2 The DM-2 will automatically adjust the fan speed until the desired pressure is achieved.



Tip Click once to change pressure by 5 Pa, hold to increment by 10 Pa.

Tip Press **[Exit]** to turn the fans off and cancel the “set pressure”.

22 Software results

22.1 Press **[Mode]** until “PrB” appears on both gauges.



22.2 Record “PrA” and “PrB”, from all gauges, to be entered into the software later.

Note Most software applications require building and fan flow pressures to be input from the gauges in Pascals (Pa).

Note Because multiple fans are being controlled by one DM-2, Flow, EqLA and other results are not applicable.

23 Pressurization testing (optional)

23.1 Remove the fans from the door and install them so that they are blowing into the building.

24 Field gauge check recommended weekly

- 24.1 Insert a T in the yellow tube.
- 24.2 Connect the red and yellow ports to the T.
- 24.3 Increase the fan speed and compare PrA and PrB.
- 24.4 Disconnect tubes from yellow and red ports and connect them to green and blue ports.
- 24.5 Repeat the test.
- 24.6 Values should be within 1% of each other.
- 24.7 Repeat the test for the second DM-2.



25 Using 3 DM-2 gauges

- 25.1 Retrotec recommends one gauge per fan to increase the number of types of test that can be performed.
- 25.2 Connect one DM-2 to each drive enabling flow to be measured on each gauge and added for a total measurement.

Note The remaining red tube goes through the door panel.

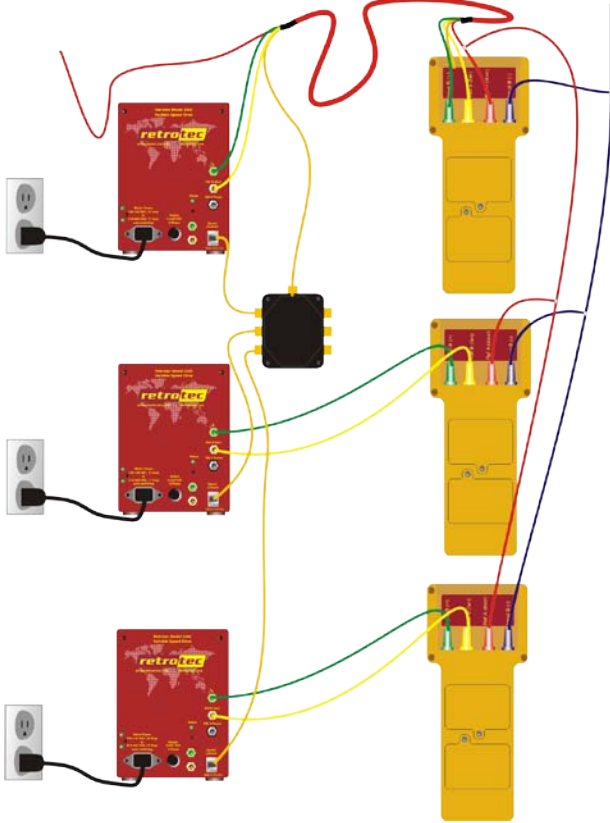

26 Setting up a 6-Fan system

- 26.1 If additional airflow is required, six fans can be connected and controlled together.
- 26.2 Connect two three-fan panels using the Connector Plate. The fan holes should be oriented towards the middle.



- 26.3 The panels must be placed opposite the direction the doors open.

27 Securing the 6-Fan system

- 27.1 Secure the panels using the retention straps, by placing the anchors through the door hinge gap.

Note The cross braces will not be usable unless the double doors have a center column.

- 27.2 Use a corner brace in each of the top corners to secure the top of the panels.

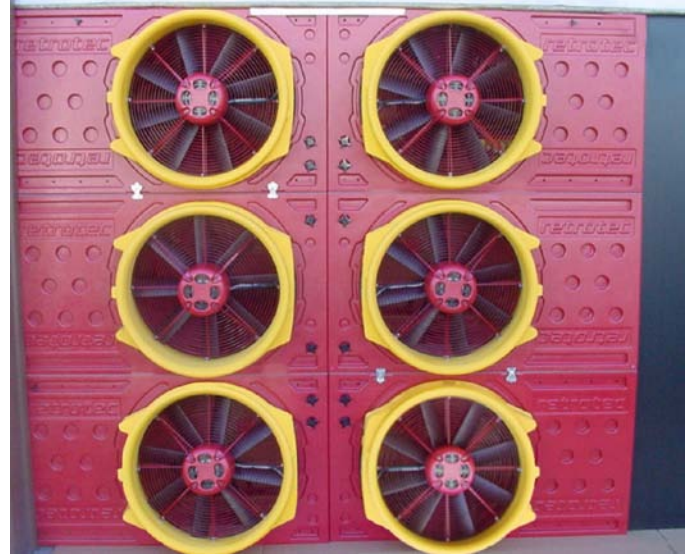

- 27.3 Use Grill Mask to cover any gaps if the panels do not completely cover the doorway.

28 Connect the fans to the splitter box

- 28.1 Connect each fan to a variable speed drive.
- 28.2 Connect all six speed drives to the same splitter box.

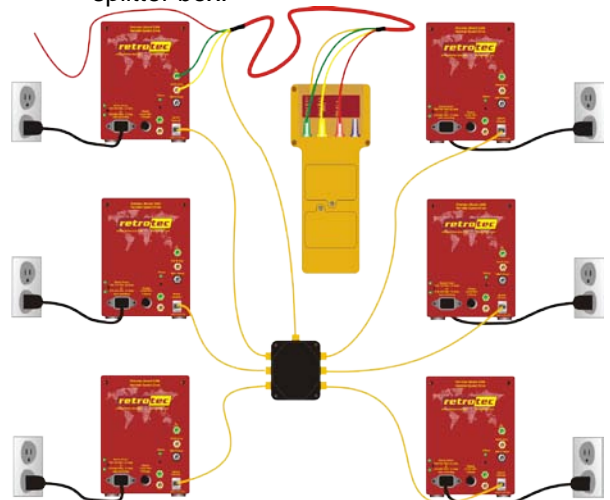

- 28.3 Connect DM-2 #1 to the splitter box using the umbilical.
- 28.4 Connect DM-2 #1 to one variable speed drive, using the yellow and green pressure tubes in the umbilical.